

**Large volume DSC with the THEMYS ONE 3D DSC detector**

**GENERAL INTRODUCTION**

The plate-type DSC technique is today a largely used technique for the thermal investigations of materials up to very high temperature (1600°C). However the main limitation of the technique is the small amount of material that can be investigated. In the case of weak thermal effects or also for experiments on non homogeneous samples, the results provided by the plate-type DSC technique are most of the time very poor.

In order to provide a better solution for these types of investigations, Setaram has selected the technology developed around the Calvet principle (3D) sensors that has been successfully used for many years in the development of calorimetric detectors. Based on this expertise, a 3D DSC detector was designed to be used on the THEMYS ONE DSC for the Cp determination at high temperature, but also for the investigation of large amounts of samples up to 1600°C.

The THEMYS ONE 3D DSC rod has benefited from the development of a thermopile made of a series of thermocouples, matching with the philosophy of Calvet principle. Platinum and platinum-rhodium wires are successively soldered side by side of the alumina structure of the measurement rod (Figure 1). This network of 9 thermocouples connected in series allows the sensor to get a relatively high sensitivity at high temperature.

The sample holders made up of platinum-rhodium have a capacity of 380 µl. Platinum-rhodium was selected for both high temperature and corrosion resistance, and for its ability to screen thermal radiations that could influence the measurement. It is also recommended to use a platinum-rhodium cover.

The large volume of the THEMYS ONE 3D DSC detector has to be compared with the volume of the THEMYS ONE plate DSC detector that is limited to 100 µl (Figure 2). Moreover the calorimetric detection with a surrounding detector is much more accurate than a detection only through the bottom of the crucible.

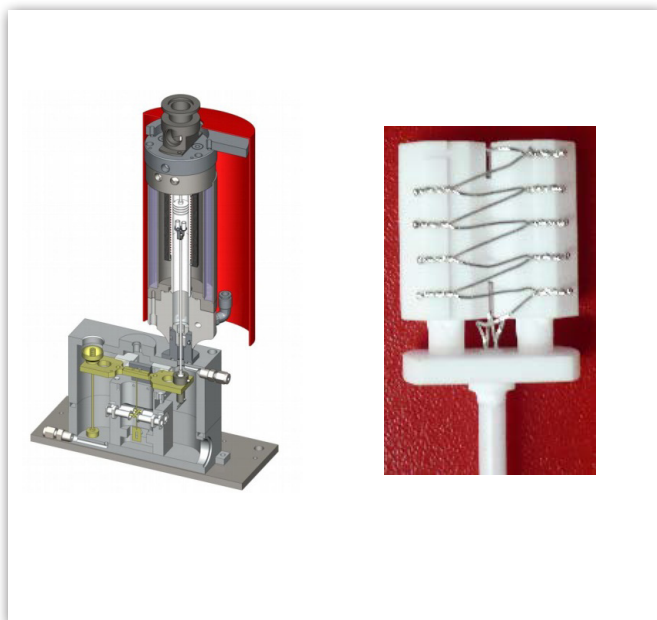

*Figure 1: Cross section of the THEMYS ONE thermoanalyzer and the Cp 3D DSC detector*

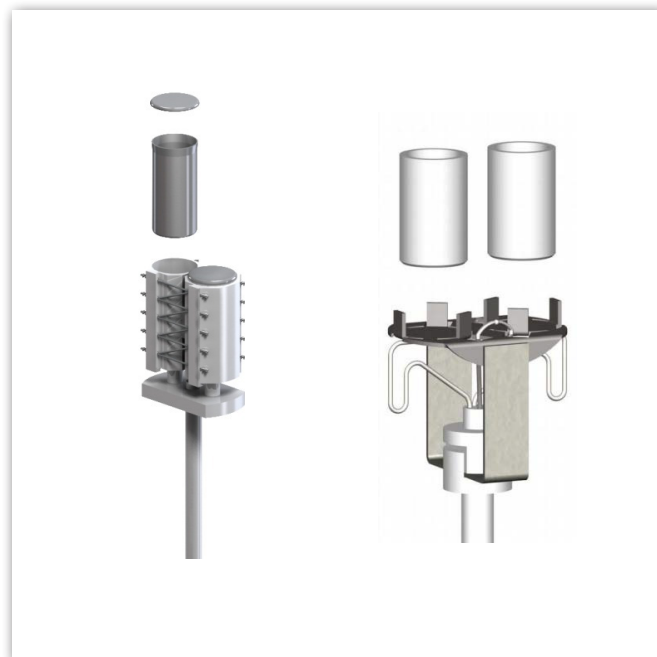

*Figure 2: Comparison between the Cp 3D DSC detector and the plate-type DSC detector*

# 1. Comparison between the THEMYS ONE 3D DSC and DTA: investigation of a borosilicate glass

## EXPERIMENT

In order to show the interest of using the THEMYS ONE 3D DSC rod compared to a classical DTA rod, a comparative test is run on a borosilicate glass at 10°C/min under argon in a platinum crucible. With the 3D DSC rod it is possible to work on a sample mass of 464 mg when only 36 mg are investigated with the DTA detector. In both cases two successive heatings are applied to the samples.

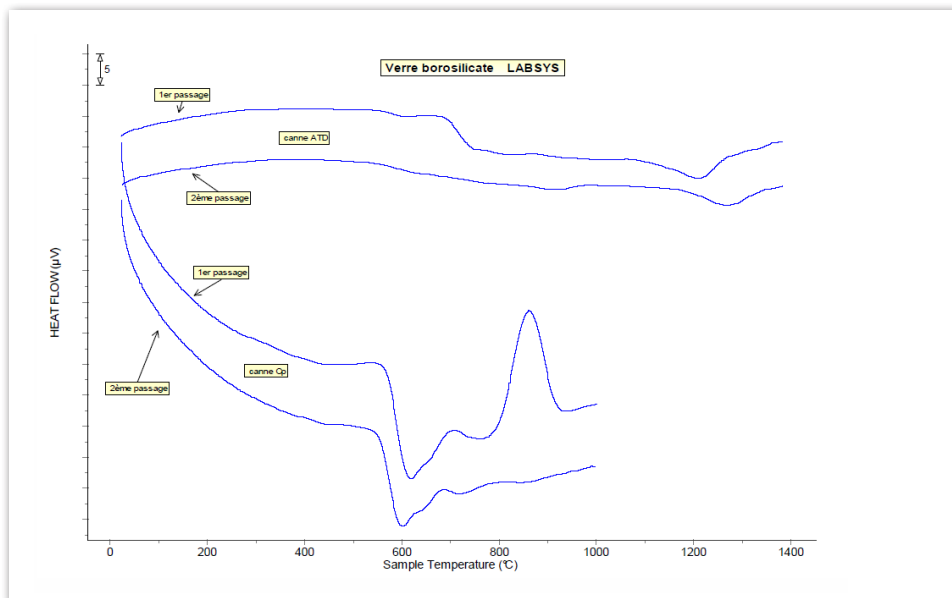

Figure 3: Investigations of borosilicate glass with the 3D DSC detector and the DTA detector

## RESULTS AND CONCLUSION

The DTA curves (Figure 3) hardly show the glass transition of the glass around 600°C. The following crystallization effect (corresponding to the crystallization of the amorphous phase) is more difficult to be clearly identified. At higher temperature is detected the endothermic melting of the glass.

With the 3D DSC detector, the glass transition and the crystallization effects are magnified and very easy to detect (the glass melting was not measured in that case). On Figure 4 is accurately determined the glass transition temperature during the two runs and the crystallization enthalpy (during the first run).

This test on a borosilicate glass clearly shows the advantage of using the 3D DSC rod when it is needed to have a clear detection of weak transitions or widespread thermal effects (such as glass transition).

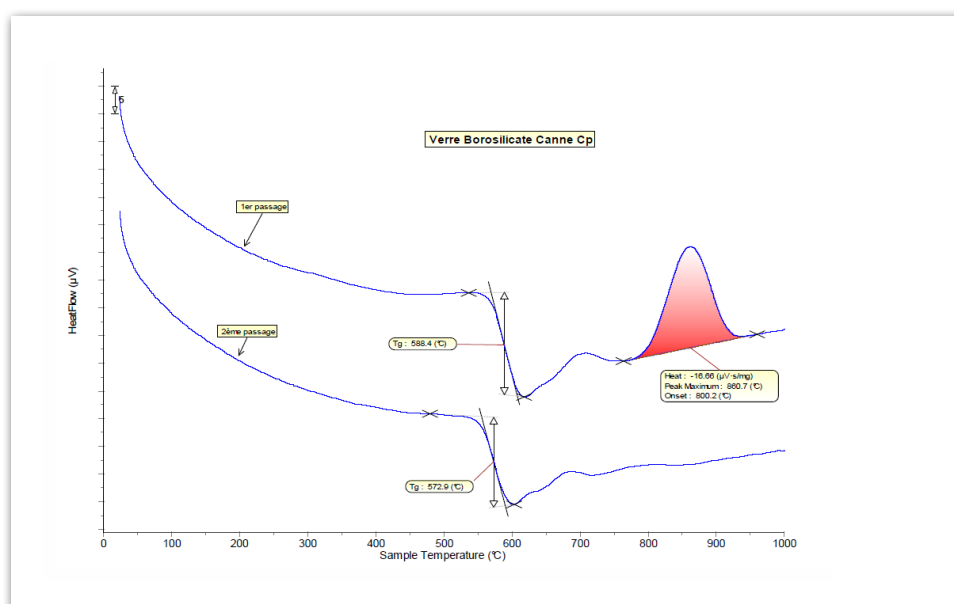

Figure 4: Glass transition and crystallization of borosilicate glass with the 3D DSC detector

## 2. Comparison between the THEMYS ONE 3D DSC and DSC: Investigation of a barium based amorphous glass at different scanning rates

### EXPERIMENT

Lead containing glass has been one of the most popular materials due its excellent stability against devitrification, high refractive index and low melting point. However due to the harmful effects of lead, the research for the production of lead free crystal glass has increased. Barium is one solution to replace lead.

Such a barium based amorphous glass is investigated using the 3D Cp rod on 305 mg of sample.

Two different samples are investigated at 5°C/min and 20°C/min.

This example was also used to compare the calorimetric obtained with the 3D DSC rod and the standard plate DSC at 20°C/min. Firstly with the plate DSC rod it was only possible to analyze 105 mg of sample when 305 mg are investigated with the 3D DSC rod.

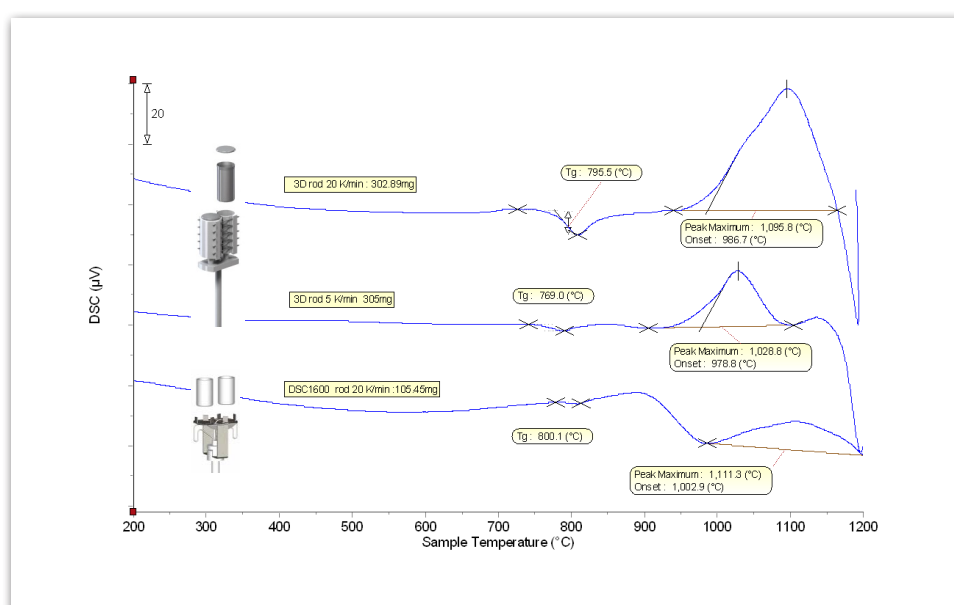

Figure 5: Glass transition and crystallization of barium based amorphous glass at 5°C/min and 20°C/min

### RESULTS AND CONCLUSION

The determination of the glass transition indicates that the T<sub>g</sub> temperature is shifted to a higher temperature when the scanning rate increases (769°C to 795.5°C) corresponding to a kinetic effect. In the same time, the same kinetic influence is detected on the crystallization effect as the maximum temperature of the crystallization peak (temperature at which the crystallization rate is maximum) is moved forward from 1028.8°C to 1095.8°C when the scanning rate increases from 5 to 20°C/min.

By decreasing the scanning rate, it is possible to separate the starting of the melting peak from the crystallization effect.

In this example, it is seen that the use of a low scanning rate with the 3D DSC detector allows a good detection of weak transitions.

According to the higher mass and the higher sensitivity provided by the 3D detector, it is clearly shown that the 3D DSC detector provides a much better detection for the glass transition of the material, but also a better definition of the exothermic peak of crystallization.

### 3. Investigation of transitions in nickel-chromium alloy

#### EXPERIMENT

Ni-based amorphous alloys are one of the potential engineering materials due to their high thermal stability, good mechanical properties and superior corrosion resistance even at high temperature. A nickel-chromium alloy (containing also aluminium and iron) is investigated using the 3 D DSC rod on a sample of 585 mg under argon in an alumina crucible at 10°C/min.

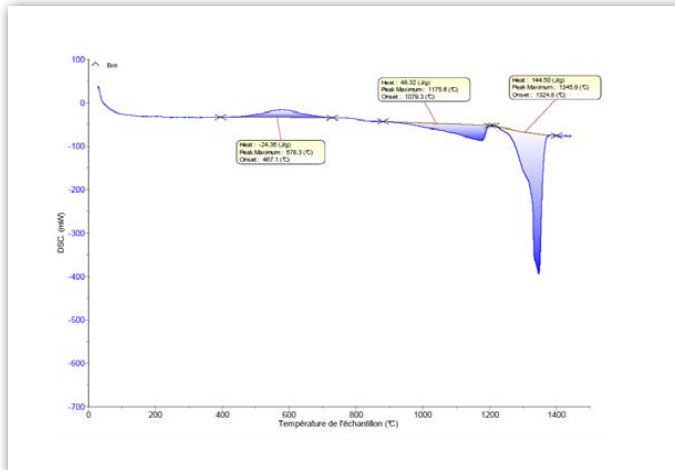

Figure 6: Heating of a Ni-Cr alloy at 10°C/min

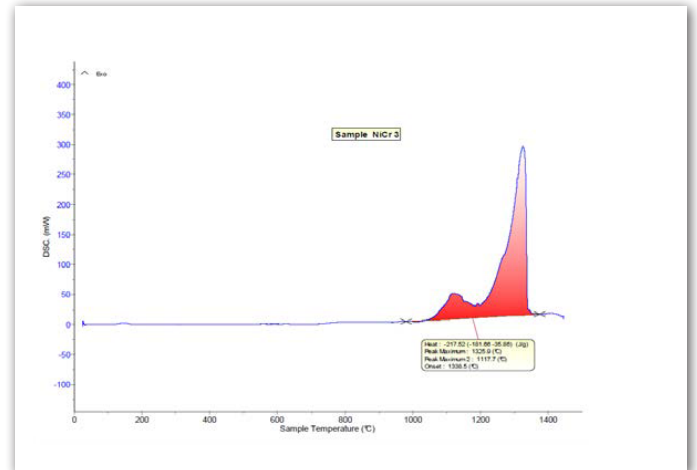

Figure 7: Cooling of a Ni-Cr alloy at 10°C/min

#### RESULTS AND CONCLUSION

A typical DSC trace obtained during heating and cooling cycle is presented. The variation of the glass transition is too small to be detectable. The first transition to be detected is the crystallization of the amorphous alloy followed by two main endothermic peaks, characteristic of solidus and liquidus reactions (Figure 6). In the cooling cycle a small undercooling is noticed with respect to the onset of solidification (figure 7).

In this experiment, the main interest is the qualification of the amorphous phase that is characterized by the preliminary crystallization peak. According to the amorphous content of nickel chromium alloy, the enthalpy of crystallization will change as seen on figure 8.

According to the sensitivity of the 3D DSC detector and the large amount of sample under investigation, it is possible to detect and measure very small exothermic enthalpies of crystallization, and in accordance small amorphous content, as seen on figure 8.

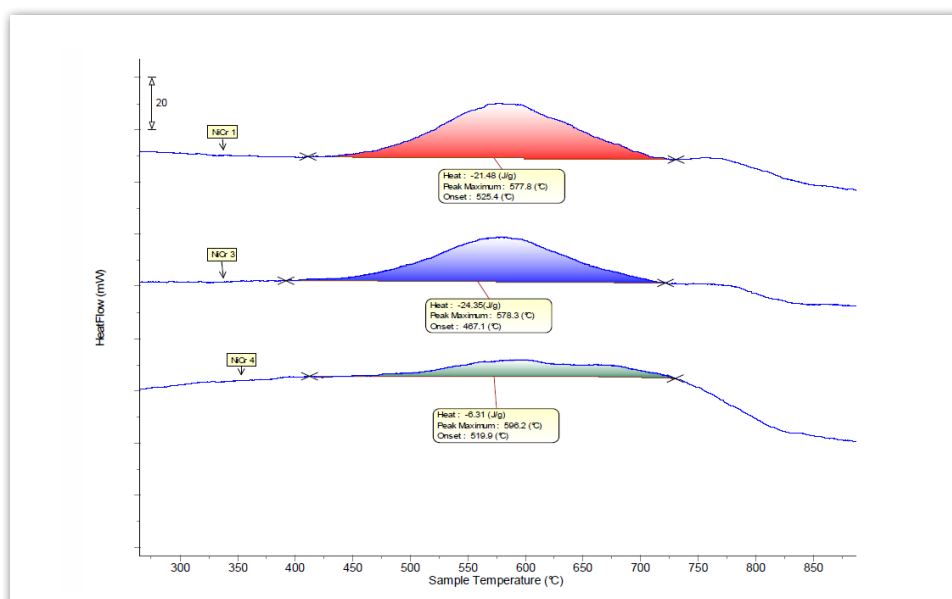

Figure 8: Crystallization of different Ni-Cr alloys at 10°C/min

## GENERAL CONCLUSION

The 3D DSC technology provides a new way of investigating transitions of materials with a high sensitivity and accuracy. According to the large amount of sample that can be investigated, the detector is well designed for the investigations of weak transitions at high temperature.

One of the main applications of the 3D DSC detector remains the Cp determination at high temperature. For more information, see the corresponding technical note TN682.

## INSTRUMENT

### THEMYS ONE



**HIGH SENSITIVITY BALANCE FOR THE DETECTION OF SMALL MASS VARIATIONS**  
specifically designed for TGA analysis.

**CONVENIENCE OF ONE FURNACE**  
to reach temperatures as high as **1150°C or 1600°C**.

**PLUG AND PLAY INTERCHANGEABLE RODS**  
to perform TGA only, TG-DSC, TG-DTA, and 3D high sensitivity/Cp measurements.

**EXTERNAL COUPLING CAPABILITY**  
including evolved gas analysers.